

Data and Computer Communications

**Chapter 1 – Data Communications,
Data Networks, and the Internet**

Eighth Edition

by William Stallings

Lecture slides by Lawrie Brown

Contemporary Data Comms

- trends
 - traffic growth at a high & steady rate
 - development of new services
 - advances in technology
- significant change in requirements
 - emergence of high-speed LANs
 - corporate WAN needs
 - digital electronics

A Communications Model

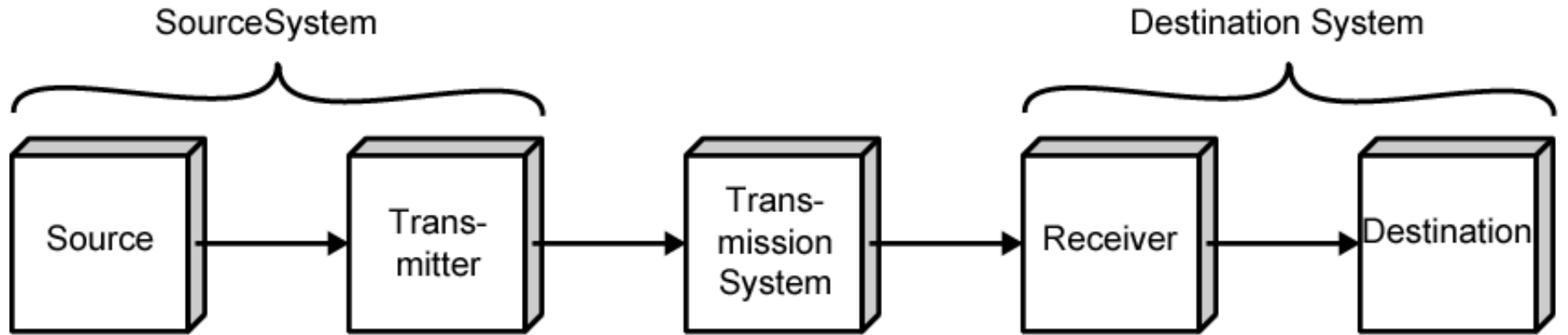

(a) General block diagram



(b) Example

Communications Tasks

Transmission system utilization	Addressing
Interfacing	Routing
Signal generation	Recovery
Synchronization	Message formatting
Exchange management	Security
Error detection and correction	Network management
Flow control	

Data Communications Model

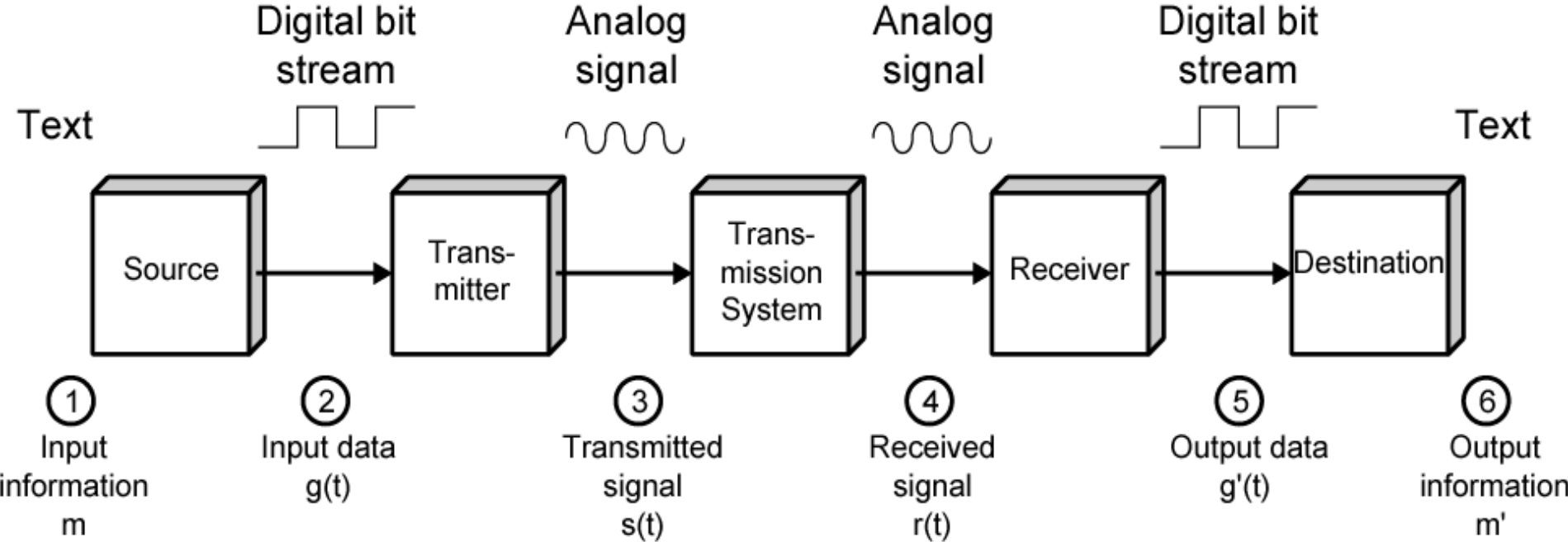

Transmission Medium

- selection is a basic choice
 - internal use entirely up to business
 - long-distance links made by carrier
- rapid technology advances change mix
 - fiber optic
 - wireless
- transmission costs still high
- hence interest in efficiency improvements

Networking

- growth of number & power of computers is driving need for interconnection
- also seeing rapid integration of voice, data, image & video technologies
- two broad categories of communications networks:
 - Local Area Network (LAN)
 - Wide Area Network (WAN)

Wide Area Networks

- span a large geographical area
- cross public rights of way
- rely in part on common carrier circuits
- alternative technologies used include:
 - circuit switching
 - packet switching
 - frame relay
 - Asynchronous Transfer Mode (ATM)

Circuit Switching

- uses a dedicated communications path established for duration of conversation
- comprising a sequence of physical links
- with a dedicated logical channel
- eg. telephone network

Packet Switching

- data sent out of sequence
- small chunks (packets)of data at a time
- packets passed from node to node between source and destination
- used for terminal to computer and computer to computer communications

Frame Relay

- packet switching systems have large overheads to compensate for errors
- modern systems are more reliable
- errors can be caught in end system
- Frame Relay provides higher speeds
- with most error control overhead removed

Asynchronous Transfer Mode

- ATM
- evolution of frame relay
- fixed packet (called cell) length
- with little overhead for error control
- anything from 10Mbps to Gbps
- constant data rate using packet switching technique with multiple virtual circuits

Local Area Networks

- smaller scope
 - Building or small campus
- usually owned by same organization as attached devices
- data rates much higher
- switched LANs, eg Ethernet
- wireless LANs

Metropolitan Area Networks

- MAN
- middle ground between LAN and WAN
- private or public network
- high speed
- large area

The Internet

- Internet evolved from ARPANET
 - first operational packet network
 - applied to tactical radio & satellite nets also
 - had a need for interoperability
 - led to standardized TCP/IP protocols

Internet Elements

